



TachMatch™ Model TM-03 Instructions

Thank you for your purchase of the TachMatch TM-03 (Rev A) from TechnoVersions LLC. The TachMatch has been designed to accommodate a variety of input and output configurations to make your tachometer work properly. It will:

- Accept various tachometer input signals (e.g., coil, MSD, HEI, ECU),
- Convert the signal from the engine to match a tachometer expecting a different number of cylinders or requiring a different input signal

The TachMatch TM-03 is designed to work with several types of tachometers:

- Most tachometers which are standard voltage-driven configuration, with one wire giving the input signal to the tachometer, typically from the coil (-) post.
- The TachMatch I-Drive can also drive current-driven tachometers that were used in some of the cars of the seventies and eighties, such as early Datsun's, cars using Smith's tachometers labeled RVI, and some of the tachometers in domestic cars. These tachometers can typically be identified by a loop of wire on the back of the tachometer. When a current-driven tach is connected to the TachMatch, is it also necessary to install a power resistor which is included with the TachMatch I-Drive module, otherwise it is the same as the standard TachMatch TM-03.
- The TachMatch TM-03 can also be used with vintage tachometers, such as the early Sun, Stewart Warner and Radatron units. These tachometers originally used a control box, which is replaced by the TachMatch TM-03. With this type of tachometer, you calibrate the output of the TachMatch, via its adjustment potentiometer, to make the tachometer read 4,000 RPM from the calibration signal of the TachMatch.

Summary of Setup and Configuration:

Tach Type	Wiring (Page 3)	Jumper J2 (Page 5)	Tach-Cyl	Eng-Cyl	Trigger Input
Standard Voltage-Driven	Top diagram	Middle "Norm"	Set to how many cylinders the tachometer expects (1-8)	Set to how many cylinders the engine has (1-8)	One connection only: Top pin for ECU, or next-to-top pin for coil, MSD or HEI.
Current-Driven	Middle diagram	Bottom "I-Dr"			
Vintage	Bottom diagram	Top "Vint"	Set to 9		

Installation:

The first installation step is to physically locate the TachMatch. It should be located inside the car (best), or if in the engine compartment, away from dirt, moisture and hot items such the exhaust and radiator. It should not be mounted next to sources of electrical noise, such as spark plug wires.

To access the terminal strip and internal switch, use a small Phillips screwdriver to remove the screw on the back of the unit, and then remove the cover. Take care that the circuit board does not touch ground or other wires during installation, doing so could damage the unit.

If you have a current-driven tachometer, the power resistor, included in the I-Drive configuration, should be mounted to a surface in an area where it can cool. It generates heat during operation. Use the provided screws to fasten it to a panel on your vehicle which has free flowing air around it. **Important: Do not forget to include this resistor in the wiring, or the TachMatch may over-heat, or damage to your vehicle may occur!**

There are only four wires for the TachMatch module to be fully operational. The terminal strip accommodates wires from 14 AWG to 22 AWG. 18 AWG is a good size to use since it fits well in the enclosure slots. Strip approximately 1/4" – 5/16" of insulation from the wires for connection to the terminal strip.

Here's the TachMatch layout in more detail:

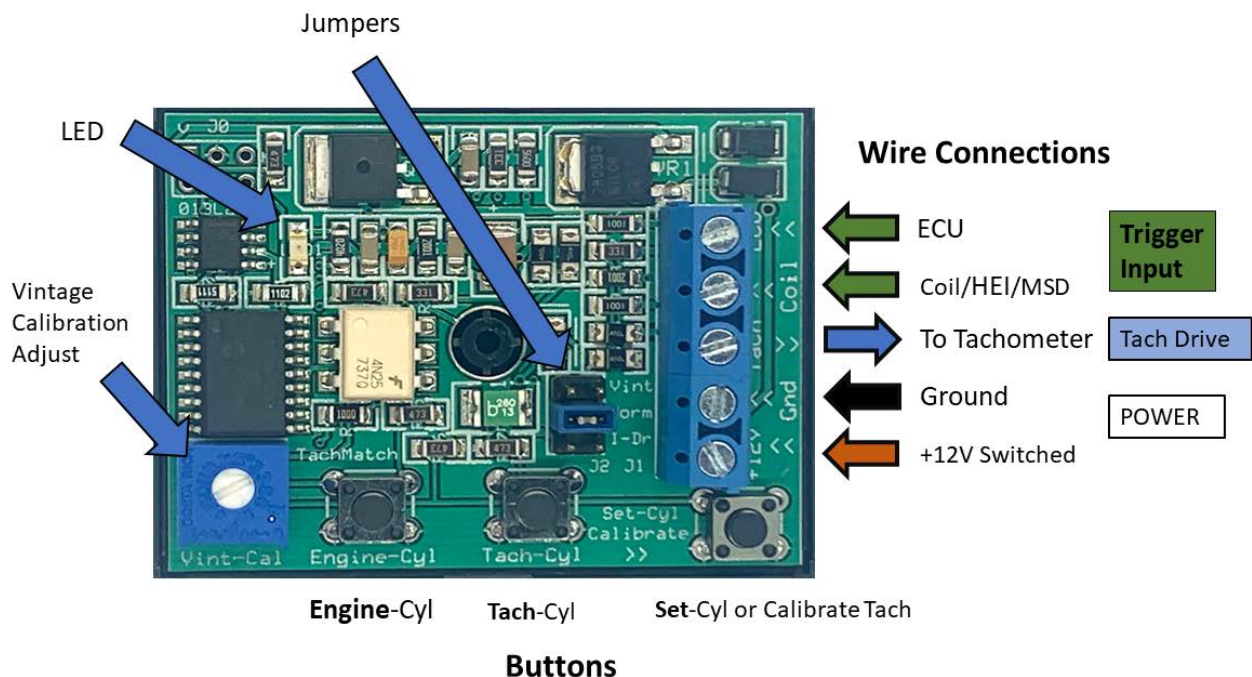

The LED illuminates when power is applied, but goes out when the engine is running, as an indication that triggering is occurring. It is also used for setting the engine and cylinder count.

Setting the Jumper:

The TachMatch TM-03 has a three-by-two header strip labeled J2. A single jumper is necessary across one of the rows:

- The jumper is installed on the **Norm** position for most tachometers (factory default for voltage-driven tachometers)
- If you have a current-driven tachometer, place it on the **I-Dr** position. **Note: DO NOT place it in the I-Dr position unless you are also using the external power resistor available from TechnoVersions. Failing to do so will damage the TachMatch, and possibly your vehicle as well.**
- If you are controlling a vintage tachometer, place the jumper on the top **Vint** position

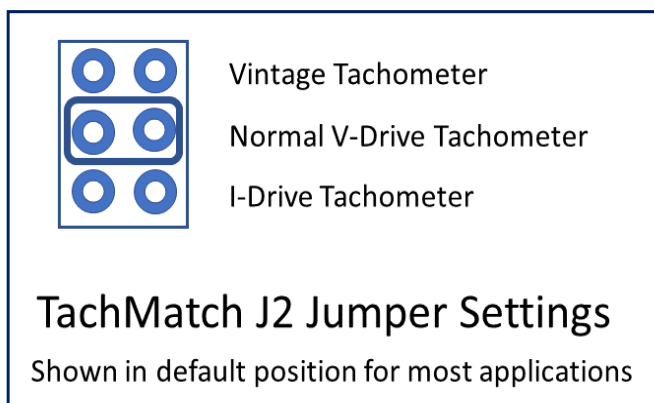

Wiring:

Note: in the following drawings, the trigger input is always shown as to a coil, but should be connected to either pin 5 (ECU), or pin 4 (coil, MSD, or HEI) as appropriate for your installation.

For a typical voltage-driven Tachometer, the TachMatch is wired as follows:

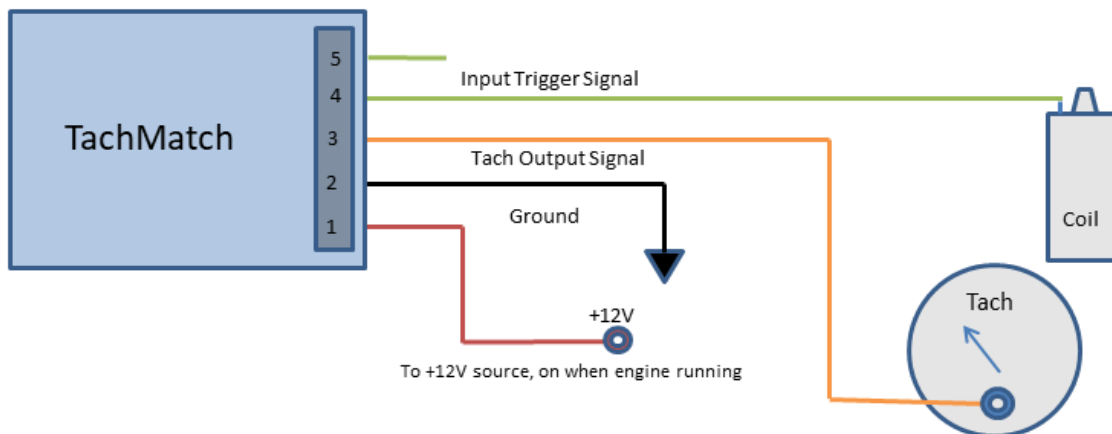

A current-driven tachometer is connected this way:

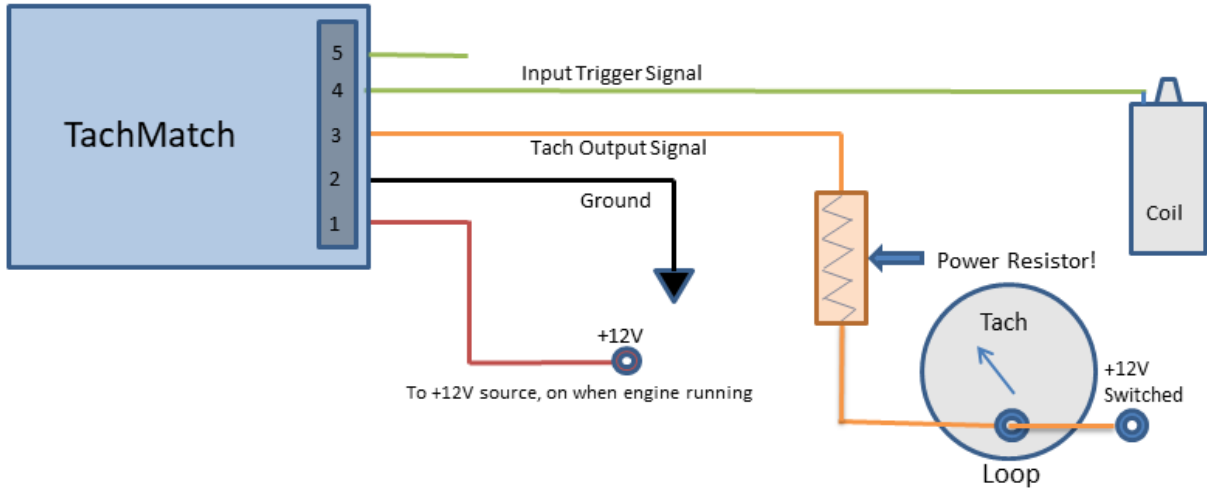

A Vintage Tach is connected this way – remember the need for a ground wire from the negative terminal of the tachometer (**Note:** to prevent damage to your tachometer, don't install the wire to the tach until the jumper, calibration potentiometer and cyl-switches are set as described on the following pages):

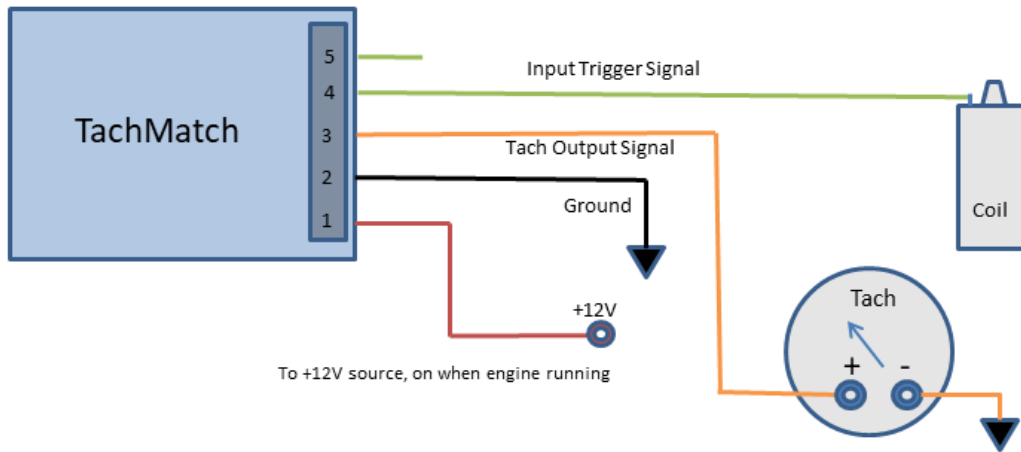

Summary of wiring connections:

Pin	Use	Connection
5	ECU trigger input	This input is used when triggering from an ECU. It includes a pull-up resistor. This input is limited to low ECU-type voltages, do not connect a coil or HEI input to this pin, or it will damage the TachMatch. If this pin is used, leave pin 4 unconnected.
4	Standard trigger input	This wire tells the TachMatch how fast the motor is turning. It can be connected to one of several types of inputs. <ol style="list-style-type: none"> (1) If you are using a standard points-style ignition, it should be connected to the terminal on the coil that goes to the points or electronic module (usually marked "-"). (2) If you are using an HEI distributor, it is connected to the Tach output on the distributor. (3) If you are using a multiple-spark or boosted ignition such as an MSD unit – DO NOT connect the TachMatch to the coil. It will not work because of the multiple spark signals, and is likely to damage the TachMatch because of the high voltages present. For these types of ignition systems, connect to their tachometer output signal. If this pin is used, leave pin 5 unconnected.
3	Tach output	This is the wire that connects to the tachometer input terminal. Note that if you are driving a current-driven tachometer, the power resistor (included with I-Drive TachMatch) MUST be installed between the Tach Output terminal and the tachometer. This is not the same as a ballast resistor, which your car may have.
2	Ground	This wire should be connected to a well-grounded surface. The ground wire is important for the TachMatch to work properly.
1	Switched +12 V	This is power to the TachMatch. It should be connected to a source of +12V when the vehicle ignition switch is turned on, and with no voltage if the vehicle is turned off. It only requires a few mA of current so can be added to most circuits without changing the existing fuse of the circuit. TachMatch voltage needs to be a minimum of 7.5 V DC for proper operation.

Cylinder Switches:

The TachMatch TM-03 has three buttons and an LED that are used for set up. The buttons are labeled **Engine-Cyl**, **Tach-Cyl**, and **Set-Cyl** which is also labeled **Calibrate**.

The **Engine-Cyl** button is used to specify how many cylinders that the engine has. Cylinders can be set between one and eight. To find out what the setting is, press and release the **Engine-Cyl** button – the LED will then flash once for each cylinder. For example, if it is set for a four-cylinder engine, it will flash four times. If the TachMatch is not triggered (engine not running), it will then come back on and stay on, but you should only count the flashes prior to that.

To change the setting, press and hold the **Engine-Cyl** button. Once it has stopped blinking, press the **Set-Cyl** button to change the setting. Each press of the **Set-Cyl** button increases the count by one, then blinks to show the current setting, after which you may press it again. Repeat the number of times necessary to get to the desired setting. When eight is reached, it rolls around to one. It ignores button-presses until it is done blinking after each press.

Note: Some engines, like the GM LS-series, have a tach signal that is like a 4-cylinder engine, even though they are 8-cylinder engines. In this case, you would set engine-cylinders to four.

The **Tach-Cyl** button is used to specify how many cylinders the tachometer was designed for. For example, if it is an eight-cylinder tach, you would want to set it to eight. To find out what the setting is, press and release the **Tach-Cyl** button. To change it, hold down the **Tach-Cyl** button and then press the **Set-Cyl** button. Setting it works just the same as the **Engine-Cyl** button. The only difference is that it goes from one to nine, then rolls around to one again. To specify that you are using the Vintage Tach function, set the **Tach-Cyl** setting to nine.

At any time, you can check your settings by individually pressing the **Engine-Cyl** or **Tach-Cyl** buttons to see what the present setting is.

Tachometer Calibration:

The **Set-Cyl** button (also labeled “Calibrate”), when pressed and held by itself, causes the TachMatch to output an approximate 4,000 RPM signal, based on the **Tach-Cyl** setting.

If you are controlling a vintage tachometer, it is necessary to make an adjustment via a potentiometer labeled **Vint-Cal**. To protect your tachometer, prior to applying power, set the potentiometer fully counter-clockwise. Turn on your ignition switch so that the unit has power. The engine does not need to be running during this process. Press and hold the **Set-Cyl** button, then adjust the potentiometer to make the tachometer read 4,000 RPM. The potentiometer is only active for vintage tachometers.

For non-vintage tachometers, the test signal will verify that the TachMatch output circuit is working properly with your tachometer. If your tachometer is not accurate, you can adjust the

output within about 25% of the reading. To do this, hold down the **Set-Cyl** button to make a 4,000 RPM signal, then press and release the **Tach-Cyl** button to move the output up by 2%, or the **Engine-Cyl** button to move the output down by 3%. Do this as many times as necessary. When you finally release the **Set-Cyl** button, the correction factor is saved permanently in TachMatch memory. If you wish reset it to factory default (no correction): power-down the unit, press and hold the **Set-Cyl** button, then apply power. This will also set the default conditions of 8-cyl engine and 4-cyl tachometer.

The TachMatch also has the ability to output 500 RPM and 1,000 RPM steps from 1,000-8,000 RPM to check tachometer operation. To do this, hold down both the **Engine-Cyl** and **Tach-Cyl** buttons as you power up the unit. It initially outputs 4,000 RPM, then you can use the **Tach-Cyl** button to go up 1,000 RPM, or the **Engine-Cyl** button to go down 1,000 RPM (500 on the last step). Resume normal operation by pressing the **Set-Cyl** button.

Completing the Installation:

Once TachMatch has been wired, jumper installed and cylinders buttons set, it is ready for use. Install the top of the protective case so that the wires nest into the slots in the end of the top cover, and install the screw from the bottom of the unit. You should now be able to fire up the engine and see your tach work properly.

In case of Problems:

If the tachometer does not work correctly, recheck your connections to ensure that they are correct and securely fastened. If it still doesn't work, TachMatch has provisions to help find out what the problem is. Try the following debugging steps:

1. With the ignition turned on, but without the engine running, you should see the TachMatch LED turned on. If it is not, the problem may be from no 12V coming into pin 1, or improper ground connection to pin 2. This LED should light even if the tachometer input and output wires (pins 3, 4 and 5) are not connected.
2. With the ignition turned on and the **Set-Cyl** button pressed, your tachometer should indicate 4,000 RPM. If it reads the wrong RPM, ensure that the **Tach-Cyl** setting is correct. If your tachometer is not active, it may be due to incorrect wiring, a bad tachometer, or the TachMatch is not compatible with your tachometer. The trigger signal wire does not need to be connected for the 4,000 RPM output to be active.

Some tachometers require a larger voltage than that provided by the TachMatch, and similar signals such as MSD tachometer output. The TachMatch V-Boost, available from TechnoVersions can be used to amplify the signal. See the TechnoVersions web page for more details.

3. Start the motor. The LED should go off while the motor is running. It turns off each time it senses an input pulse, so at low RPMs you will see it as a flashing LED and at high

RPMs it will appear to be steadily off. If the LED stays on steady when the motor is running, TachMatch is not receiving a trigger signal from the engine. Recheck the connection to the coil, distributor, ECU or tachometer output.

After going through these steps, if you are not able to make your TachMatch unit work properly, please contact us via email at TachMatch@aol.com for support.

Limited Warranty & Return Policy

TechnoVersions LLC provides a limited warranty for TachMatch. If a unit should fail within 180 days from time of shipment from TechnoVersions, it can be returned for repair or replacement at TechnoVersions discretion. Products subject to abuse (as determined by TechnoVersions) are excluded from this limited warranty. TechnoVersions LLC makes no other claims as to suitability and excludes any indirect or consequential damages. Risk of loss and shipping damage become the responsibility of the customer once delivered to a common carrier by TechnoVersions LLC.

Exclusive remedy is limited to product replacement or repair. Cost of shipping the product to TechnoVersions is at the customer's expense, but the replacement/repaired TachMatch will be shipped to customer at TechnoVersions expense, except for shipments out of the USA, in which case TechnoVersions shipping cost is limited to the cost of domestic shipments. When returning a unit to TechnoVersions LLC, please include a description of the problem to help facilitate repair.

If a TachMatch unit does not work properly in your application, and is not damaged, TechnoVersions will allow return for full refund of purchase cost, exclusive of any shipping charges. Claim for such must occur within 30 days of product shipment from TechnoVersions. Ship the unit back to TechnoVersions along with a description of the problem and date of purchase. TechnoVersions will remit the refund via PayPal refund within 10 working days of product receipt.